



传感器原理		MH C	MH C2
电气参数			
测量角度范围	°	0 ... 360	0 ... 360
独立线性度	% of meas. range	±0.3	±0.1
最大磁滞	°	0.1	0.1
分辨率	bit	12	14
Max. repeatability	°	0.1	0.1
快速模式采样率	kHz	(5)	(2)
慢速模式采样率	kHz	1.66	0.5
快速模式系统传播延迟	µs	(800)	(800)
慢速模式系统传播延迟	µs	4600	2500
输出信号最大温度系数	ppm/°K	50	50
MTTFd / MTBF	years	668/668	308/308
供电电压	VDC	5 (±10 %)	5 (±10 %)
不带负载电流损耗(typ.) 快速模式	mA	(14)	(15)
不带负载电流损耗(typ.) 慢速模式	mA	9	10
输出最小电阻负载	kOhm	10	10
输出最大电容负载	nF	100	100
电源极性反接保护		yes	no
电气连接		Cable 3pole	Cable 3pole
单根线缆横截面	mm²	0.56 (AWG20)	0.56 (AWG20)
冗余		yes	no
电气连接冗余		Wires (6x)	-
单根线缆横截面 冗余	mm²	0.56 (AWG20)	-
机械特性参数			
机械转角范围	°	360 (continuous)	360 (continuous)
防护等级		IP54 / IP65	IP54 / IP65
在特定防护等级的最大起动转矩	Ncm	0.5 / 3	0.5 / 3
最大回转速度	rpm	120	120
最小寿命	movements	50 Mio.	50 Mio.
最大允许轴向轴负载	N	20	20
最大允许径向轴负载	N	20	20
工作和储存温度(with cable)	°C	-40 ... +85	-40 ... +85
工作和储存温度(with 线缆)	°C	-40 ... +125	-40 ... +125
IEC 68-2-6振动(Amax = 0.75mm, f = 5 ... 2000 Hz)	g	20	20
IEC 68-2-27冲击	g	50	50

符合标准

EN 55022 class B, Emission radiated (30... 230 MHz)	dB(µV/m)	max. 30	max. 30
EN 55022 class B, Emission radiated (230...1000MHz)	dB(µV/m)	max. 37	max. 37
EN 61000-4-2, ESD (contact discharge / air discharge)	kV	±4 / ±8	±4 / ±8
EN 61000-4-3, Immission HF radiated (80... 1000 MHz)	V/m	30	30
EN 61000-4-4, Burst (on all lines)	kV	±1	±1
EN 61000-4-5, Surge (lines to ground)	kV	±1	±1
EN 61000-4-6, Immission HF conducted (0.15...80MHz)	Vemk	10	10
EN 61000-4-8, Immission magnetic field (50Hz)	A/m	30	30
IEC 60393-1 Insulation resistance (500VDC, 1bar, 2s)	GOhm	20	20
IEC 60393-1 Dielectric strength (VAC, 50Hz, 1min, 1bar)	kV	1	1

Vert X 28 5V 10 90 Ub

应用
收割机
叉车
工作台
液压泵

特点 general

小体积
非接触式测量方法
很长的寿命
高精度测量
带扩展孔调节器
已编程电气角度范围内
全分辨率和精确

特点 MH-C
线性度 ±0.3%
分辨率 of 12bit
完全冗余
比MH-C2更便宜

特点 MH-C2
线性度 ±0.1%
分辨率 14bit
索引点, 旋转方向和角度
可设定/可编程
(可选)



Vert X 28 5V 10 90 Ub

订购代码
开关输出
请定义一个数字
(最大. 127), 位置和宽度脉冲

<p>输出特性</p> <ul style="list-style-type: none"> 正向梯度 CW标准1 正向梯度 CCW可选2 冗余, 正向梯度 CW可选3 冗余, 正向梯度 CCW可选4 冗余, 交叉信号曲线可选5 正向梯度 CW 带1路开关输出*可选A 正向梯度 CCW 带1路开关输出*可选B 正向梯度 CW 带2路开关输出*可选C 正向梯度 CCW 带2路开关输出*可选D 旋转方向可设定可选E 零点和旋转方向可设定可选F 中点和旋转方向可设定可选G 起始点和终点旋转方向可设定可选H 可编程Vert-X EasyAdapt可选P <p>输出信号</p> <ul style="list-style-type: none"> 10% ... 90% Ub标准2 x% ... y% Ub (within 5 ... 95%)可选4 <p>供电电压</p> <ul style="list-style-type: none"> 5VDC标准2 	<p>电气连接</p> <ul style="list-style-type: none"> 1标准圆形电缆 3pole 2可选线缆 4pole 3可选线缆 5pole 4可选线缆 6pole 9可选特殊电缆 / 线缆 <p>Length of 线缆</p> <ul style="list-style-type: none"> 01可选10cm 03可选30cm 05标准50cm 99可选特殊长度 <p>电缆长度</p> <ul style="list-style-type: none"> 02标准1.0m 06可选3.0m 10可选5.0m 99可选特殊长度
--	---

Vert X 2 8 0 1 7 3 6 2 2 1 1 0 2

<p>机械特性版本</p> <ul style="list-style-type: none"> 2801标准6mm 轴D-shape; IP54 2821可选耦合触发; IP54 2831标准6mm 轴 D-shape; IP65 2841可选耦合触发; IP65 2899可选特殊轴 	<p>电气转角</p> <ul style="list-style-type: none"> 36标准电气转角 360° xx可选03 to 35; Declaration in 10° steps 99可选特殊转角 <p>传感器原理</p> <ul style="list-style-type: none"> 7MH-C 8MH-C2
---	--

定制轴设计	MH C	MH C2
定制电缆/ 线缆	X	X
接口x% ... y% Ub (within 5% ... 95% Ub)	X	X
快速模式采样率	X	X
开关功能TTL (max. 2)	X	X
特殊特性曲线	X	X
特殊电气转角 范围30° to 360° (咨询工厂)		X
电气转角可编程 (软件)	X	X
起始点和终点可设定 (额外线缆)		X
旋转方向CW/CCW 可设定 / 可编程 (额外线缆或软件)		X
索引点可设定 / 可编程 (额外线缆或软件)		X
		X

可选 (根据客户需求)



Vert X 2801
Vert X 2831
 配件 (incl.)
 None

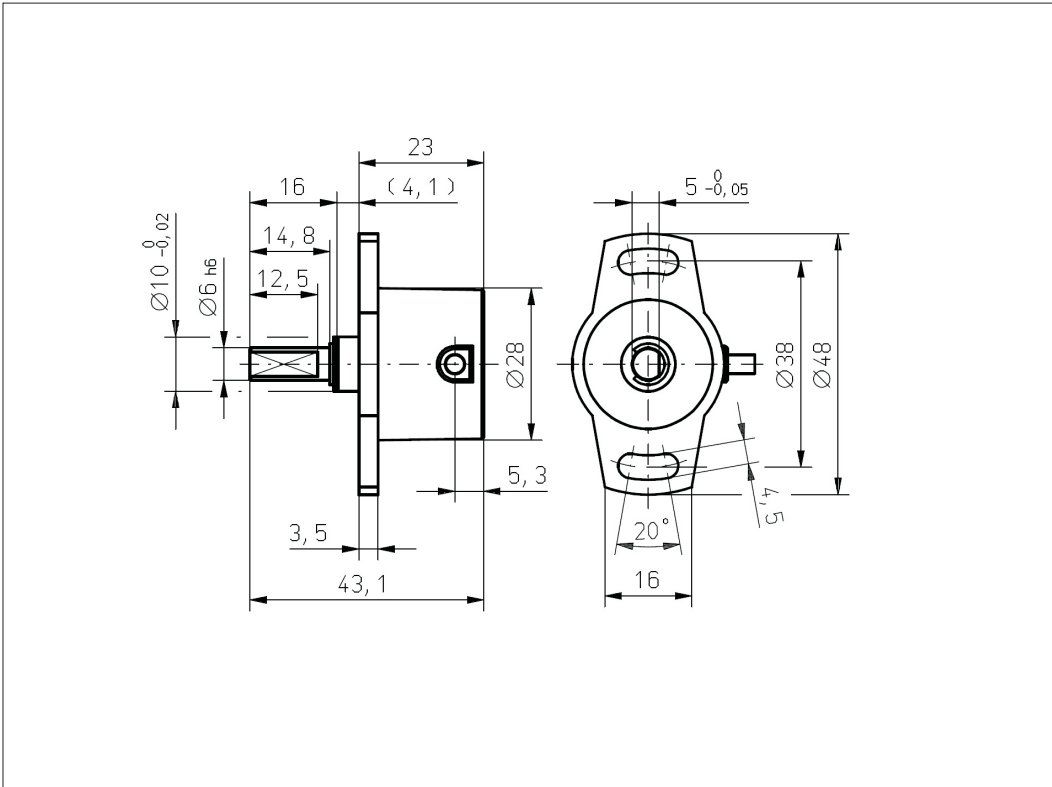

Vert X 2821
Vert X 2841
 配件 (incl.)
 None

